



Centrum stavebního inženýrství a.s., Praha  
Centre of Building Construction Engineering Prague

Akreditovaná zkušební laboratoř, Autorizovaná osoba, Notifikovaná osoba, Certifikační orgán  
Accredited Test Laboratory, Authorised Body, Notified Body, Certification Body  
Zlín Site - K Cihelně 304, 764 32 Zlín - Louky

Product Type Initial  
**TEST REPORT**

In accordance with Section 5, Subsection 1, Letter b) of Government Decree No. 190/2002 Coll., as amended (Conformity Assessment System 3) and in compliance with Council Directive 89/106/EEC of 21 December 1988 on the approximation of laws, regulations and administrative provisions of the Member States relating to construction products (Construction Products Directive - CPD) as amended by Council Directive 93/68/EEC of the European Communities of 22 July 1993.

**No. 1390 – CPD – 0126 – 10/Z(e)**

\* Translation of Initial Type Testing Report No. 1390 – CPD – 0126 – 10/Z

Job Order No.: 963 807  
Application Filing No.: 0126/10/Z

No. of copies: 2  
Print No.: 1  
No. of pages in the Report: 3

Product Name:

**CRYSTAL HP TUBŮLAR SKYLIGHT**

The Centre of Building Construction Engineering Prague, Zlín Site, as Notified Body No. 1390, assessed the execution of an initial test for the above-mentioned product type. This Report may be used as grounds for the issuance of a CE Declaration of Conformity according to the requirements of the harmonized standard ČSN EN 14351-1:2006 for

manufacturer/production plant:

**LIGHTWAY, s.r.o.**

Ledvinova 1714, 149 00 Prague 4 / Hostivická 13/22, 155 21 Prague 5  
Czech Republic

Company Identification Number: **63 669 366**

Report executed by:

Ing. Jindřich Mrlík

*Handwritten signature*

Notified Body Manager:

Ing. Petr Kučera, CSc.



In: Zlín, 4 January 2010

Caution: This Report may not be reproduced in any other way than in its entirety without the written consent of the Notified Body.

Centre of Building Construction Engineering Prague, Zlín Site, K Cihelně 304, 764 32 Zlín - Louky, Czech Republic  
Bank Contact: KB Prague 10, Account No.: 2901-101/0100, Company Identification Number: 45274860, Tax Identification Number: CZ45274860  
Phone: +420 577 604 111, Fax: +420 577 104 926, E-mail: [jindrich.mrlík@csizlín.cz](mailto:jindrich.mrlík@csizlín.cz), [www.csias.cz](http://www.csias.cz)



## 1 SPECIFICATION OF THE TEST SUBJECT

### 1.1 Specification of the Specimens and Product Description

The **CRYSTAL HP TUBULAR SKYLIGHT** is formed by three basic elements:

- the roof part is formed by a *dome* with a flashing plate
  - the inner part consists of a diffuser
  - the central part interconnects the parts stated above and is called the body tube
- the *skylight* is composed of a glass dome and flashing plate. The flashing plate is made of ABS material 3 mm in thickness, the surface is a semi-gloss finish, the design is orange peel. The parts are joined using bolts and washers (see Fig., Detail D). The gasket to the body tube is a brush type, 8 mm Linear with Acryl, supplied by Okentés.
- the diffuser consists of a holder anchored to the ceiling, in which the diffuser's transparent filler is mounted
- the body tube forms a system of tubes with reflective inner surfaces

spec. no.	body tube, dia. (mm)	designatio n	description
479	152	200 HP	specimen of the smallest delivered dome
493	320	400 HP	complete, assembled tubular skylight

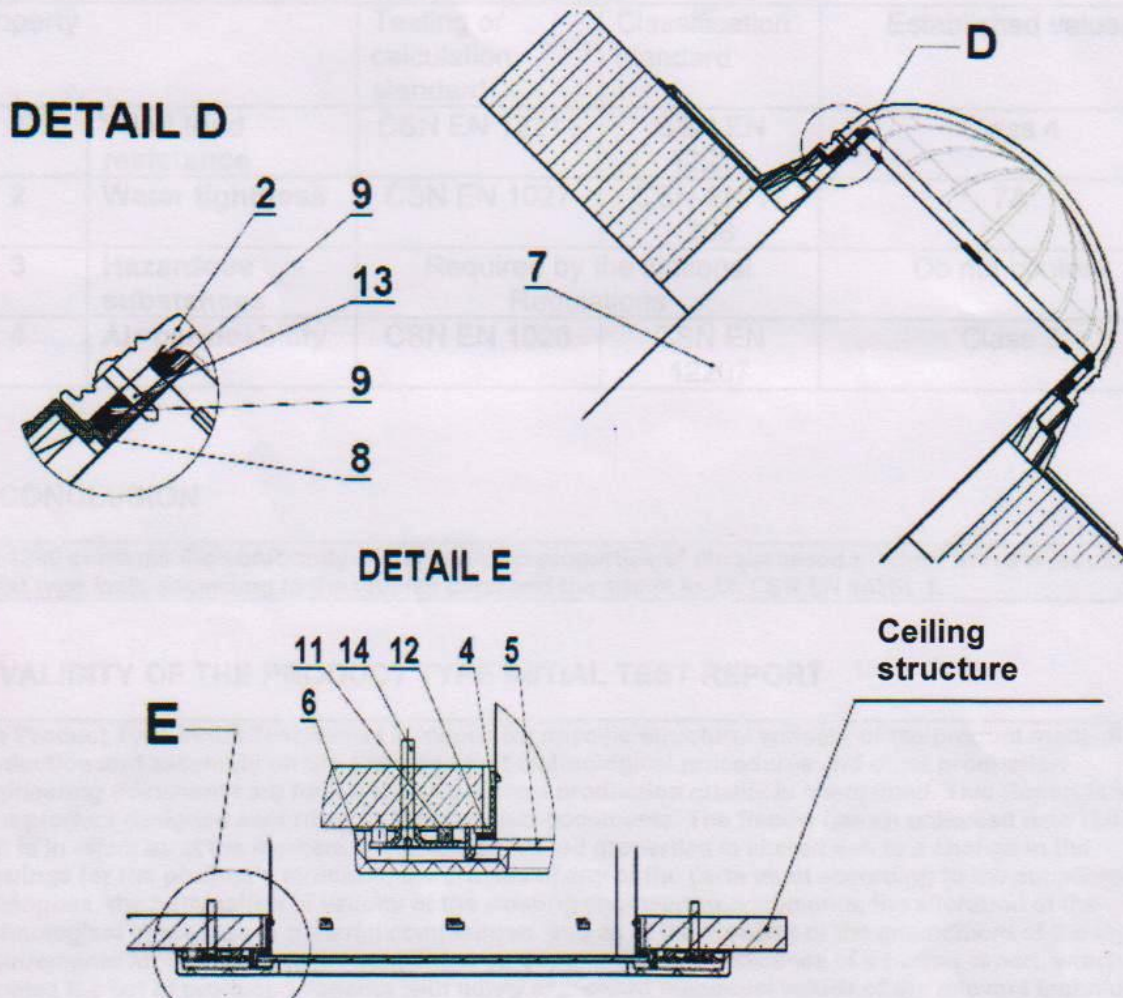

**1.2 Product Purpose:** The tubular skylight is intended for the ceiling illumination of premises. It is suitable for both flat and pitched roofs. The product is designed for use in both residential and industrial buildings, to which no fire-reaction or fire-resistance requirements pertain. The tubular skylight also has heat-insulation and sound-proof as well as protective functions against adverse climatic influences.



## 2 SAMPLING

Specimen taken by: František Brandalík - LIGHTWAY s.r.o., Ledvinova 1714/12, 149 00 Prague 4 - Chodov  
Specimen supplied by: František Brandalík - LIGHTWAY s.r.o., Ledvinova 1714/12, 149 00 Prague 4 - Chodov

Date of delivery of the specimens to the Test Laboratory: 17 and 31 October 2007

Specimen filing numbers: see Chapter 1.1 Specification of Specimens

## 3 TEST RESULTS

The initial product type tests were performed by Accredited Testing Lab. No. 1007.1 – Centre of Building Construction Engineering, Zlín Site, K Cihelně 304, 764 32 Zlín. The results of the tests are given in the Reports as referred to in Chapter 6.

The assessment of the properties of hazardous substance leakage was conducted using an indirect method. The materials used do not contain any hazardous substances as declared by the manufacturer.

Table 1 – Tabulation of the results of initial product type tests

Property		Testing or calculation standard	Classification standard	Established values
1	<b>Wind load resistance</b>	ČSN EN 12211	ČSN EN 12210	Class 4
2	<b>Water tightness</b>	ČSN EN 1027	ČSN EN 12 208	7A
3	<b>Hazardous substances</b>	Required by the National Regulations		Do not content
4	<b>Air permeability</b>	ČSN EN 1026	ČSN EN 12207	Class 3

## 4 CONCLUSION

NO 1390 confirms the conformity of the declared properties of the assessed product with the results of initial type tests according to the articles used and the annex to ZA ČSN EN 14351-1.

## 5 VALIDITY OF THE PRODUCT TYPE INITIAL TEST REPORT

The Product Type Initial Test Report is issued for specific structural variants of the product made during production and assembly on the condition that technological procedures and other production engineering documents are followed and constant production quality is maintained. This Report is valid for a product designed according to the provided documents. The Report has an unlimited time validity or it is in effect as at the moment any of the assessed properties is altered due to a change in the drawings for the product's structure, the change of any of the parts used according to the suppliers' catalogues, the termination of validity of the existing engineering documents, the alteration of the technological procedure or material composition, and as at the moment of the amendment of the legal requirements for the product assessment or as at the moment of issuance of a further report, which updates the list of produced variants with newly expressed numerical values of the relevant technical parameters and physical quantities.

## 6 GROUNDS USED FOR THE EXECUTION OF THE REPORT

1. Report No. 396/07 on the tests, as at 1 November 2007, Centre of Building Construction Engineering, Zlín Site, K Cihelně 304, 764 32 Zlín.